

General

Applications for SCREWLINE Pumps

Dry Compressing Scroll Vacuum Pumps	SCREWLINE SP 250 (ATEX)	SCREWLINE 630 (F) ATEX
Application		
Food processing	■	■
Vacuum coating	■	■
Lamination	■	■
Loadlock chambers	■	■
Mechanical engineering	■	■
Automotive industry	■	■
Metallurgy/Furnaces	■	■
Crystal pulling	■	■
Degassing	■	■
Electrical engineering	■	■
Energy technology	■	■
Welding technology	■	■
Lamps/Tubes manufacture	■	■
Cooling and air conditioning	■	■
Chemistry/Pharmaceuticals	■	■
Chemical research laboratories	■	■
Vacuum drying	■	■
Freeze drying systems	■	■
Environmental engineering	■	■
Packaging	■	■
Medical technology	■	■
Analytical engineering	■	■
Research and development	■	■
Space simulation	■	■
Backing pump for HV-Systems	■	■

Products



Screw Vacuum Pump SCREWLINE SP 630

The Screw Vacuum Pumps SCREWLINE were developed in view of the special requirements of industrial applications. The innovative design allows these pumps to be used whenever reliable, compact and low maintenance vacuum solutions are required.

Principle of Operation

Screw Vacuum Pumps are dry compressing backing pumps, the operation of which is based on the screw principle. The pumping chamber of the pump is formed by two synchronised positive displacement rotors and the housing enclosing these. Since the rotors rotate in opposite directions, the chambers move steadily from the intake to the exhaust side of the pumps thereby resulting in a smooth pumping action (see figure below). Since with a single Screw Vacuum Pump rotor pair a multistage compression process is implemented, the component count in the pumping path is very low. In this way maintenance and servicing work is much simplified.

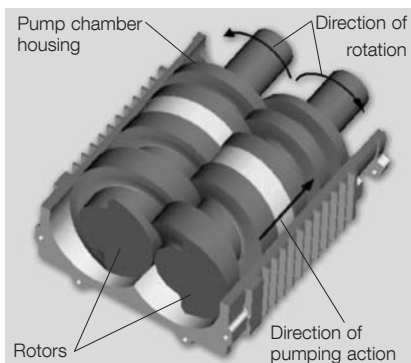

Principle of operation of the SCREWLINE Line

Properties

The direct pumping path without multiple deflections for the medium make the Screw Vacuum Pumps highly insensitive to foreign materials. This ensures a high uptime in industrial processes.

The two non-contacting shaft-seals are practically wear-free, which allows for very long maintenance intervals. Shaft seal purge is usually required in industrial applications. SCREWLINE pumps are equipped with a purge gas supply unit.

Because of the cantilevered bearing arrangement for the Screw Vacuum Pump rotors, a potential source of failure (i.e. a bearing on the intake side) is entirely eliminated. On the one hand, no lubricants from the bearings can enter into the vacuum process, and the other hand also an impairment of the bearing by aggressive process media can be excluded.

A further benefit of the cantilevered bearing arrangement is the easy

accessibility of the pump chamber. This innovative design feature allows the removal of the pump housing without time-consuming and costly disassembly of the bearings. Thus on-site cleaning of all surfaces in contact with the medium is possible. In particular, if the processes involved considerable amounts of contaminants this is a significant advantage which ensures a long uptime.

The low exhaust temperature is an important advantage of the Screw Vacuum Pumps. Owing to the design of the screw rotors, a temperature of maximum 100 °C (212 °F) is attained inside the pump. Thus deposits of many substances are avoided which react at high temperatures. This makes the pump unique and many customers, above all from the field of coating, value this highly.

Should deposits form in spite of this, then the easy to disassemble housing facilitates rapid cleaning.

Besides the integrated oil cooling arrangement for the rotors, the Screw Vacuum Pumps are air-cooled from the outside. Here rotor and housings are thermally linked via the oil cooler. Thus, Screw Vacuum Pumps adapt themselves ideally to the ambient conditions under changing operating situations.



Oil/water cooling unit SP 630 F

A water-cooled version is offered as Screw Vacuum Pumps SP 630 F. This product version is intended for operation in air-conditioned rooms.

The Screw Pumps portfolio is completed through ATEX-certified variants.

Moreover, the Screw Vacuum Pumps portfolio also includes pump versions suited for pumping pure oxygen (O₂).

Maintenance and Monitoring

During the development of the Screw Vacuum Pumps, special emphasis was placed on a particularly simple maintenance concept. This has been implemented through the cantilevered bearing arrangement, with all maintenance components and controls having been located on the so-called service side for easy accessibility. Thus, the space requirement which needs to be taken into account during planning has been optimized. The lower space requirement gives the user more flexibility during installation of the pump.

The monitoring system SP-GUARD was developed especially for constant real-time monitoring of the operational status of the Screw Vacuum Pumps. The operating parameters are con-

stantly acquired and processed. This enables the user to introduce preventive actions early enough so as to ensure trouble-free operation of his Screw Vacuum Pumps. The key current operating parameters can be read off from a local display. Moreover, connection to a PLC and remote monitoring is possible. Maintenance of the Screw Vacuum Pumps will generally be limited to a regular visual inspection of the pump and the annual change of gear oil and oil filter. The oil fill ports as well as the filters are readily accessible and can be easily exchanged.

With the aid of a flushing kit (optional) it is possible to clean the pump chamber, while the pump is operating without process. Deposits due to the process can thus be removed effectively and quickly without the need of having to disassemble the housing.

Also, cleaning of the air/oil heat exchanger can be done simply on-site by blowing out the heat exchanger with compressed air.

Accessories

Screw Vacuum Pumps offer to the user a high degree of flexibility. Inlet and exhaust connections are made through universal flanges, respectively clamped flanges, permit simple integration within the system. Through the accessories which are available, the pump can be optimally adapted to the individual requirements of differing applications.

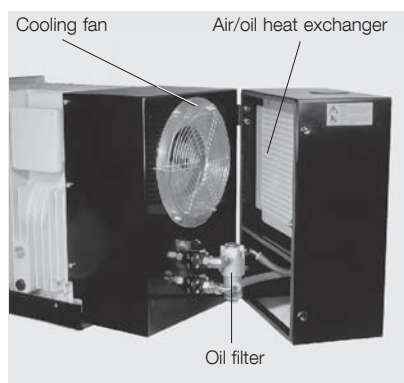

Oil/water cooling unit SP 630

Advantages to the User

- Utmost reliability
- Protection of the pump through monitoring vital parameters by means of the SP-GUARD
- Minimum downtimes owing to rapid cleaning of the pump chamber (in less than one hour)
- Avoidance of deposits through low internal temperatures
- Minimum operating costs
- The only directly air cooled screw vacuum pump on the market. No need for cooling water
- No seal gas needed for standard applications
- No oil in the pump chamber. Thus no need for disposing of contaminated oil
- Gear oil change only every two years
- Utmost flexibility
- Direct adaptation of RUVAC pumps for increased pumping speed up to approximately 7000 m³/h
- Multi-flange for all commonly used pipe connections
- Flushing kit for constant cleaning of the pump chamber
- Silencing hoods for a further reduction of noise emissions

Typical Applications

- Industrial furnaces
- Coating technology
- Load lock chambers
- Metallurgical systems
- Food processing
- Drying processes
- Degassing
- Research and development
- Lamps and tubes manufacture
- Automotive industry
- Packaging industry
- Space simulation
- Electrical engineering
- Energy research

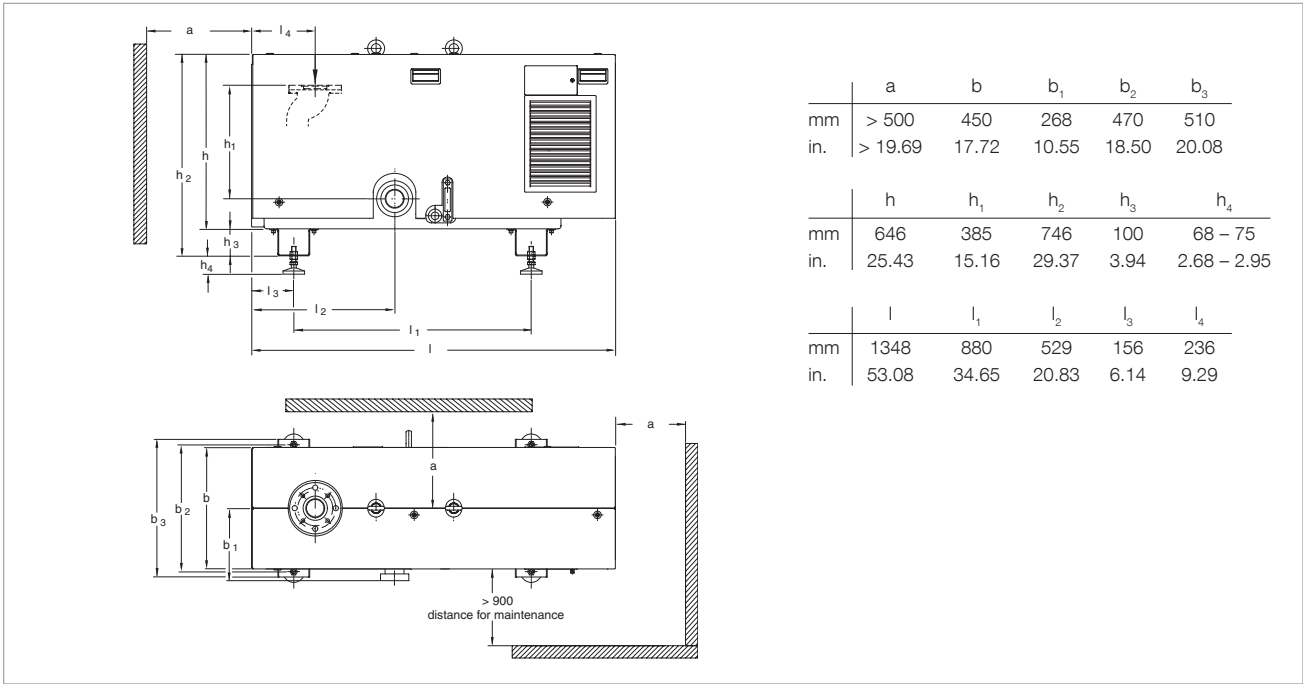

Dimensional drawing for the SCREWLINE SP 250

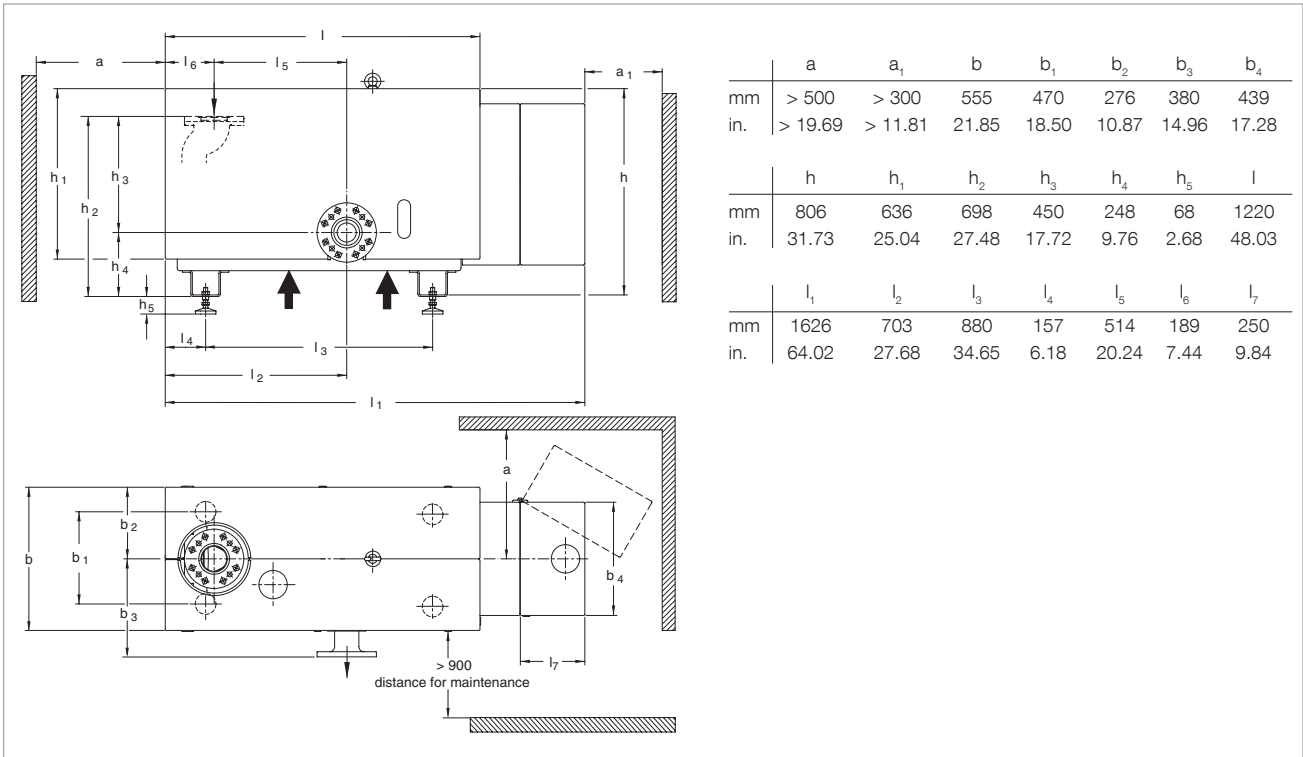

Dimensional drawing for the SCREWLINE SP 630

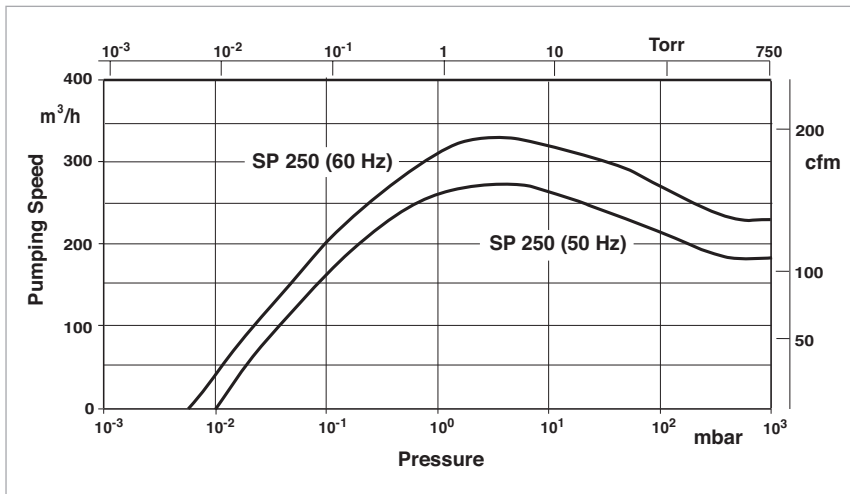

Effective pumping speed of the SCREWLINE SP 250 for air, without gas ballast (50/60 Hz)

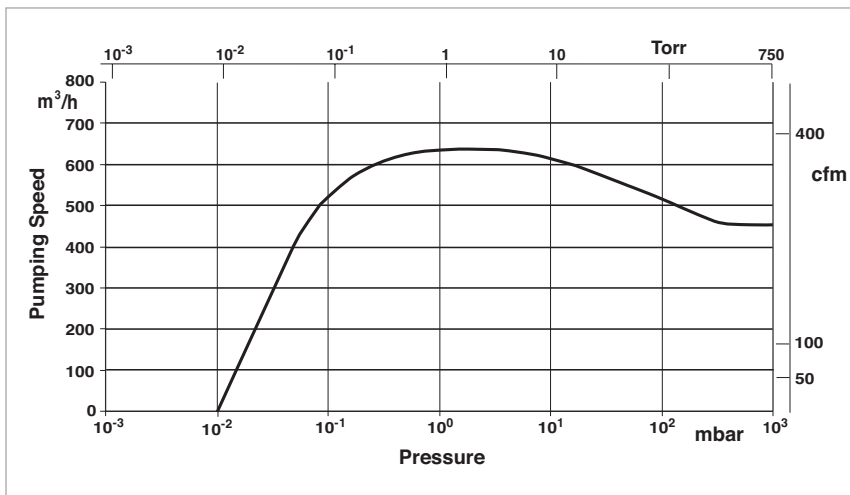

Effective pumping speed of the SCREWLINE SP 630 for air, without gas ballast

Technical Data

SCREWLINE SP 250

50 Hz

60 Hz

		50 Hz	60 Hz
Effective pumping speed	m ³ /h (cfm)	270 (157)	330 (194)
Ultimate pressure, total	mbar (Torr)	≤ 0.01 (≤ 0.0075)	≤ 0.005 (≤ 0.0038)
Permissible intake pressure, max.	mbar (Torr)	1030 (773)	1030 (773)
Maximum exhaust pressure with reference to the ambient pressure		$p_{ex} = p_{amb} + 200 \text{ mbar (150 Torr)}$ $- 50 \text{ mbar (37 Torr)}$	$p_{ex} = p_{amb} + 200 \text{ mbar (150 Torr)}$ $- 50 \text{ mbar (37 Torr)}$
Permissible ambient temperature	°C (°F)	+10 to +40 (+50 to +104)	+10 to +40 (+50 to +104)
Water vapour tolerance (with gas ballast)	mbar (Torr)	60 (45)	75 (56)
Water vapour capacity (with gas ballast)	kg/h (gal/h)	10 (2.7)	18 (4.9)
Installation location		up to 3000 metres (9.800 feet) (above sea level)	up to 3000 metres (9.800 feet) (above sea level)
Cooling		Air	Air
Power supply at operating voltage	$\Delta\Delta$ Δ	32.0 A / 200 V (cos phi 0.88) 16.0 A / 400 V (cos phi 0.88)	31.5 A / 210 V (cos phi 0.88) 15.5 A / 460 V (cos phi 0.88)
Nominal power	kW (HP)	7.5 (10.0)	7.5 (10.0)
Power consumption at ultimate pressure	kW (HP) kW (HP)	5.9 (8.0) at 3-ph. 200 V / 400 V 6.5 (8.8) at 3-ph. 500 V	7.2 (9.8) at 3-ph. 200 V / 400 V -
Energy efficiency class		IE 2	IE 2
Motor rotational speed	rpm	2920	3505
Type of protection	IP	55	55
Thermal protection class		F	F
Lubricant filling (LVO 210)	l	7	7
Intake flange, standard			
Clamping flange		ISO 1609-1986 (E)-63 (DN 63 ISO-K) ¹⁾	ISO 1609-1986 (E)-63 (DN 63 ISO-K) ¹⁾
Bolt flange		ASME B 16.5 NPS 3 class 150	ASME B 16.5 NPS 3 class 150
Bolt flange		EN 1092-2-PN 6 – DN 65	EN 1092-2-PN 6 – DN 65
Exhaust flange, standard			
Clamping flange		ISO 1609-1986 (E)-63 (DN 63 ISO-K)	ISO 1609-1986 (E)-63 (DN 63 ISO-K)
Exhaust flange, optional			
Clamping flange		ISO 1609-1986 (E)-63 (DN 63 ISO-K) ¹⁾	ISO 1609-1986 (E)-63 (DN 63 ISO-K) ¹⁾
Bolt flange		ASME B 16.5 NPS 3 class 150	ASME B 16.5 NPS 3 class 150
Bolt flange		EN 1092-2-PN 16 – DN 65	EN 1092-2-PN 16 – DN 65
Bolt flange		EN 1092-2-PN 6 – DN 65	EN 1092-2-PN 6 – DN 65
Materials (components in contact with the gas)		Aluminum, aluminum anodic oxidised, C steel, CrNi steel, grey cast-iron, FPM (FKM) (Viton)	Aluminum, aluminum anodic oxidised, C steel, CrNi steel, grey cast-iron, FPM (FKM) (Viton)
Weight, approx.	kg (lbs)	450 (992)	450 (992)
Dimensions (W x D x H)	mm (in.)	1350 x 530 x 880 (53.1 x 20.9 x 34.6)	1350 x 530 x 880 (53.1 x 20.9 x 34.6)
Noise level ²⁾	dB(A)	67	72

¹⁾ This flange is required when ISO-K flanges are to be connected (Part No. 267 47)

²⁾ With connected exhaust gas line at ultimate pressure

Ordering Information

SCREWLINE SP 250

	Standard	ATEX	O ₂
	Part No.	Part No.	Part No.
Screw Vacuum Pump SP 250 (50/60 Hz) with manual gas ballast and purge gas unit	115 001 ¹⁾	-	-
with purge gas unit, castors and manual gas ballast valve	115 006 ¹⁾	-	-
with electromagnetic gas ballast and purge gas unit Category 3GD IIC 160 °C (320 °F) inside	-	115 003 ^{1, 2)}	-
with electromagnetic gas ballast Purge vent vit, FFPM gaskets and purge gas unit Category 2G3D b IIC 135 °C (275 °F) inside/ Category 3GD Ex nA IIC 160 °C (320 °F) outside	-	115 012V11 ¹⁾	-
with electromagnetic gas ballast and purge gas unit SP-GUARD	-	-	115 019 ^{1), 3)}
Accessories			
Exhaust silencer	119 002	119 002	119 002
Serviceable silencer	119 003V	119 003V	119 003V
Exhaust non-return valve (DN 65 PN 6)	119 011	-	-
Solenoid gas ballast kit, 24 V ⁴⁾	119 054V	-	-
Adaptor for RUVAC 501/1001	119 022	119 022	119 022
Purge gas retrofit kit	119 031	-	-
Inlet filter adapter DN 63 ISO-K	119 019	119 019	-
Dust filter	951 68	-	-
Purge vent kit	119 061V	119 061V	119 061V
Oil change kit	EK 110 000 820	EK 110 000 820	EK 110 000 820
Screw inspection kit	EK 110 000 821	EK 110 000 821 ⁵⁾	EK 110 000 821
Purge gas connection servicing kit	EK 110 000 834	EK 110 000 834	EK 110 000 834
Filter for gas ballast	E 110 000 980	E 110 000 980	E 110 000 980
Filter for purge gas valve unit	E 110 000 850	E 110 000 850	E 110 000 850
Absorbing felt	E 110 002 435	E 110 002 435	E 110 002 435
Silencer service kit	EK 500 003 476	EK 500 003 476	EK 500 003 476
Seal kit non-return valve SP 250	EK 110 000 828	EK 110 000 828	EK 110 000 828
Seal kit RUVAC adaptor SP 250	EK 110 000 835	EK 110 000 835	EK 110 000 835
Vibration element RUVAC adaptor SP 250	ES 110 000 2677	ES 110 000 2677	ES 110 000 2677

¹⁾ All pumps are equipped as standard with an SP-GUARD

²⁾ Only ATEX Category 3i (Directive 94/9/EG)

³⁾ T4 with max. $p_{ex} = p_{amb} + 200 \text{ mbar}$
 $p_{ex} = p_{amb} - 50 \text{ mbar}$

⁴⁾ This accessory item can only be used beginning with SN (serial number) 31000530865

⁵⁾ Only for Part No.

For all enquiries and orders relating to category 1 and 2 ATEX products please exclusively use our ATEX questionnaire. You can find this questionnaire at the end of the full-line catalog together with the fax forms or on the Internet under "www.leybold.com" under Download Documents in the area Documentation.

SCREWLINE SP 630

Technical Data

50 Hz

60 Hz

Effective pumping speed	m ³ /h (cfm)	630 (371)	630 (371)
Ultimate total pressure	mbar (Torr)	≤ 0.01 (≤ 0.0075)	≤ 0.01 (≤ 0.0075)
Intake pressure limits, max.	mbar (Torr)	1030 (773)	1030 (773)
Maximum exhaust pressure with reference to the ambient pressure		$p_{ex} = p_{amb} + 200 \text{ mbar (150 Torr)}$ $- 50 \text{ mbar (37 Torr)}$	$p_{ex} = p_{amb} + 200 \text{ mbar (150 Torr)}$ $- 50 \text{ mbar (37 Torr)}$
Permissible ambient temperature	°C (°F)	+10 to +40 (+50 to +104)	+10 to +40 (+50 to +104)
Water vapour tolerance (with gas ballast)	mbar (Torr)	40 (30)	40 (30)
Water vapour capacity (with gas ballast)	kg/h (gal/h)	14 (3.7)	14 (3.7)
Installation location		up to 3000 metres (9.800 feet) (above sea level)	up to 3000 metres (9.800 feet) (above sea level)
Cooling		Air	Air
Power supply	$\Delta\Delta$ Δ Y ¹⁾	56 A / 200 V 28 A / 400 V 16 A / 690 V	52 A / 210 V 24 A / 460 V -
cos φ		0.89	0.90
Nominal power	kW (HP)	15 (20)	15 (20)
Power consumption at ultimate pressure	kW (HP)	< 11 (< 15)	< 11 (< 15)
Energy efficiency class		IE 2	IE 2
Motor rotational speed	rpm	2930	3530
Type of protection	IP	55	55
Thermal protection class		F	F
Lubricant filling (LVO 210)	l	13	13
Intake flange and exhaust flange compatible with bolt flanges		EN 1092-2 - PN 6 – DN 100 EN 1092-2 - PN 16 – DN 100 ISO 1609-1986 (E)-100 (DN 100 ISO-K) ²⁾ ASME B 16.5 NPS4 class 150	EN 1092-2 - PN 6 – DN 100 EN 1092-2 - PN 16 – DN 100 ISO 1609-1986 (E)-100 (DN 100 ISO-K) ²⁾ ASME B 16.5 NPS4 class 150
Materials (components in contact with the gas)		Aluminum, aluminum anodic oxidised, C steel, CrNi steel, grey cast-iron, FPM (FKM) ((Viton))	Aluminum, aluminum anodic oxidised, C steel, CrNi steel, grey cast-iron, FPM (FKM) ((Viton))
Weight, approx.	kg (lbs)	530 (1166)	530 (1166)
Dimensions (W x D x H)	mm (in.)	1630 x 660 x 880 (64 x 26 x 35)	1630 x 660 x 880 (64 x 26 x 35)
Noise level ³⁾	dB(A)	73	75

¹⁾ 690 V upon request

²⁾ This flange is required when ISO-K flanges are to be connected (Part No. 267 50)

³⁾ With connected exhaust gas line at ultimate pressure

SCREWLINE SP 630 F

Additional Technical Data

50 Hz

60 Hz

Cooling		Water	Water
Water connection	G	1/2" ISO 228-1	1/2" ISO 228-1
Water temperature	°C (°F)	+5 to +35 (+41 to +95)	+5 to +35 (+41 to +95)
Minimum water feed pressure	bar (psi, gauge)	2 (15)	2 (15)
Nominal flow at a water feed temperature of 25° C (77 °F)	l/min (gal/min)	12 (3)	12 (3)
Noise level ¹⁾	dB(A)	71	71

¹⁾ With connected exhaust gas line at ultimate pressure

Ordering Information**SCREWLINE SP 630 Standard / SP 630 F Standard**

	50 Hz	60 Hz
	Part No.	Part No.
Screw Vacuum Pump SP 630 air cooled, with manual gas ballast	117 007	117 008
Screw Vacuum Pump SP 630 F water cooled, with adapter for RUVAC 2001 and electromagnetic gas ballast	117 105	117 106
with manual gas ballast	117 107	117 108
with purge gas kit and manual gas ballast	117 113	117 114
Screw Vacuum Pump SP 630 water cooled, with castors, purge gas kit and electromagnetic gas ballast	117 117	117 118

All pumps are equipped as standard with an SP-GUARD

Ordering Information**SCREWLINE SP 630 ATEX / SP 630 F ATEX**

	50 Hz	60 Hz
	Part No.	Part No.
Screw Vacuum Pump SP 630 with purge gas kit manual gas ballast and air cooled, Category 3G IIC (160 °C (320 °F)) inside	117 017	117 018
with purge gas kit 24 V gas ballast and water cooled, Category 3G IIC (160 °C (320 °F)) inside	117 115	117 116
Screw Vacuum Pump SP 630 F water cooled Category 2G3D IIC (160 °C (320 °F)) Category 3G IIC T3 (160 °C (320 °F)) with purge gas monitor, adapter for RUVAC 2001 and electromagnetic gas ballast	117 111V11	117 112V11

All pumps are equipped as standard with an SP-GUARD

For all enquiries and orders relating to category 1 and 2 ATEX products please exclusively use our ATEX questionnaire. You can find this questionnaire at the end of the full-line catalog together with the fax forms or on the Internet under "www.leybold.com" under Download Documents in the area Documentation.

Ordering Information**SP 630 O₂**

	50 Hz	60 Hz
	Part No.	Part No.
Screw Vacuum Pump SP 630 with purge gas monitor and electromagnetic gas ballast	117 039	117 040

All pumps are equipped as standard with an SP-GUARD

Ordering Information

SCREWLINE SP 630 Standard / SP 630 F Standard

Accessories

50 Hz / 60 Hz

	Part No.
Exhaust silencer	119 001
Serviceable silencer	119 004V
Roots pump adapter for RUVAC 1001 ¹⁾	500 003 173
for RUVAC 2001	119 021
for RUVAC WH(U) 2500 ¹⁾	155222V
for RUVAC WH 4400 ¹⁾	119 024V
Dust filter ²⁾	951 72
Elbow 90° (DN 100 ISO-K)	887 26
Clamping screws for DN 63-250 ISO-K	267 01
Centering ring for DN 100 ISO-K	268 06
Purge vent Kit	119 060V
Inlet filter adapter DN 100 ISO-K	119 020
Solenoid gas ballast kit, 24 V from serial number 31000530865	119 054V
Non-return valve (DN 100 PN 6)	119 010
Purge gas retrofit kit ³⁾	119 030
Maintenance kit, level 1 (oil change kit) up to serial number 31000197911	EK 110 000 792
from serial number 31000197911	EK 110 000 832
Maintenance kit, level 2 (rotor inspection kit)	EK 110 000 793
Purge gas connection servicing kit	EK 110 000 827
Filter for gas ballast	E 110 000 980
Filter for purge gas valve unit	E 110 000 850
Water filter maintenance kit for SP 630 F	EK 110 000 813
Silencer service kit	EK 500 003 475
Seal kit for SP 630 check valve	EK 110 000 815

¹⁾ Must mount to adapter Part No. 119 021

²⁾ For information on the dust filter please refer to the Catalog Part "Oil sealed Vacuum Pumps", Section "SOGEVAC", Chapter "Accessories"

³⁾ Not for ATEX pumps and pumps which comprise this already